

The mixer, kneading machine, eggbeater **Planet stainless steel** is excellent in laboratory use and for the confectionery, food, chemical and cosmetic industries.

For the strong structure, the high power and the very slow minimum speed of the models V and EL, it is particularly suitable for dough.

The tools turn very close to the inner wall of the bowl and mix perfectly the product, even with little doses.

The stainless steel safety guard can be raised without effort, thanks to a pneumatic system which prevents any accidental drops too.

Oil leakage with subsequent product contamination is not possible.

All moving parts are mounted on ball bearings, which do not require maintenance and make the machine steady and silent.

All the models can be equipped with a second bowl, smaller than the standard one.

Planet stainless steel can be supplied in three different versions:

 **3V Models:** with 3 fixed speed, studied to effect any kind of processing: dough, mixing and whipping.

 **V Models:** with variable speed, selected by using a dial on the control panel, indifferently while the tool is still or in motion. Speed variation is gradual and continuous, so that the appropriate speed can be selected for each type of mix and for each step of the production, without sudden speed changes or machine stoppages.

 **EL Models:** they can be easily programmed to carry out, automatically, up to 20 complete cycles of working. Their technical features are the same of V models, with an even richer equipment, including digital panel with "check control" function, revolution counter and timer.

Three system to move the bowl are available:

by lever, by hand-wheel and electric.

The machine is manufactured according to CE current standards.

TECHNICAL DATA

Model		PL 40	PL 60	PL 80
Bowl capacity	Lt.	40	60	80
Bowl dimensions	cm.	40x36h	45x42h	45x52h
Consumption	Kw.	1,5	1,5	1,5
Weight	Kg.	250	253	270
A (Bowl up and down by lever)	cm.	72	75	75
A (Bowl up and down by hand-wheel)	cm.	68	73	73
B	cm.	96	96	96
C	cm.	144	144	160
D	cm.	65	65	65
E	cm.	90	90	90

Standard accessories

- Stainless steel bowl
- Stainless steel Ø mm.4 wire whisk
- Kneading tool
- Paddle
- Instruction and maintenance manual

Optional Accessories

- Conveyor for addition of liquids
- Electrical up and down of the bowl for V and EL models
- 20 l bowl with 3 tools for 40 l models
- 30 l bowl with 3 tools for 40 l or 60 l models
- 40 l bowl with 3 tools for 60 l or 80 l models
- Timer for automatic stoppage of the tool movement
- Stainless steel Ø mm.3 wire whisk
- Electric burner with adjustable thermostat
- Bowl holder trolley
- Tools support

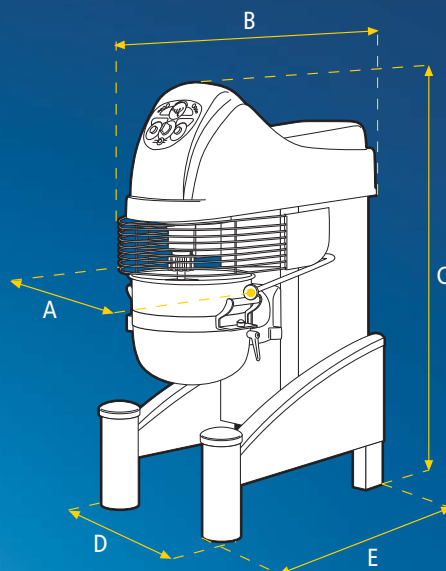

PLANET 40
stainless steel **60**
80

Steno

DEALER

www.steno.it

info@steno.it

STENO F.lli Nazzari - 27043 BRONI (PV) - ITALY - Str. Prov. n.202 delle Teste, 14/16 - Tel. +39 0385 245878 - Fax +39 0385 240686

Non binding data. The manufacturer reserves the right to make any modifications he deems necessary.

Powerful, reliable, versatile.

➔ More than a Planetary Mixer

The high power, in spite of the very reduced consumption, and the very slow minimum speed allow the mixer to work perfectly every kind of dough, even the most consistent one

More than a safety system

Easy to lift.
It cannot drop



PLANET 40
stainless steel
60
80



Reduction kit

Kit 20

Kit 30

Kit 40

Reduction kit with 20, 30 and 40 l bowls

➔ More than a beautiful line
New Look in stainless steel.
Quality and Reliability guaranteed by over 50 years' experience

3 versions for every requirement



3 speeds



Variable speed



Electronic control



Steno